

# MT-68A

## DIGITAL ATTENUATOR

Programmable Digital  
Attenuator  
200 to 6000 MHz

### OVERVIEW

The MT-68A programmable digital attenuator is a completely shielded, high performance, digitally controlled, 8-channel RF attenuator system. It is intended for any automated RF testing where high accuracy signal power control is needed. The MT-68A offers very good attenuation accuracy, high dynamic range and speed. The high performance of the attenuator is obtained through a high precision attenuator design and calibration.

### Applications

- Wi-Fi up to 802.11be and cellular technologies (GSM, UMPs, LTE-FDD, LTE-TDD, 5G-FR1) testing
- Throughput vs Range measurements
- Wi-Fi or Cellular Roaming measurements
- Mesh, Band-steering
- Receiver Sensitivity Measurements
- System design or device verification testbeds
- Engineering Development and Automated Manufacturing Test



### Key Features/Benefits

- Frequency range: 200MHz to 6000MHz
- Number of individual channels: 8
- Dynamic Range: 95 dB
- Step: 0.25 dB
- Insertion loss: 4.5dB at 2.4 GHz & 6dB at 6 GHz
- 0.1 dB compression: 34 dBm
- IP3: 58 dBm
- PoE Powered and Ethernet or USB Interface
- Programmable via Browser or APIs
- Completely shielded and very good accuracy
- Supports Windows, Linux and Mac OS

## SPECIFICATION

Parameter		Min	Typ	Max
Frequency Range (MHz)		200		6000
Impedance ( $\Omega$ )			50	
Channels			8	
Attenuation Range (dB)		95		
Shielding (dB)			110	
Isolation between Channels (dB)			90	
Step Size (dB)		0.25		
Insertion Loss (dB)	< 2.5 GHz		4.5	6
	< 6 GHz		6	7
Attenuation Accuracy (dB)			$\pm 0.25$	$\pm 1.5$
Switching Speed ( $\mu$ s)			2	
Maximum Input Level (dBm)			+28 (operating) +33 (absolute max)	
Input IP3 (dBm)			58	
Operating modes	Uni/Bi-Directional GUI control or APIs			
Power	Power over Ethernet (PoE)			
Operating Temperature	-30 °C to +70 °C			
RF connectors	SMA			
Control Interface	Ethernet or USB			
Operating System	Windows, Linux and Mac			
Custom APIs as per user requirements	Yes			

## CONNECTIONS

Port Name	Connector Type
RF in	SMA female
RF out	SMA female
USB	USB type Mini-c female
Network (Ethernet/LAN)	RJ45 socket

**Mechanical Outline:**

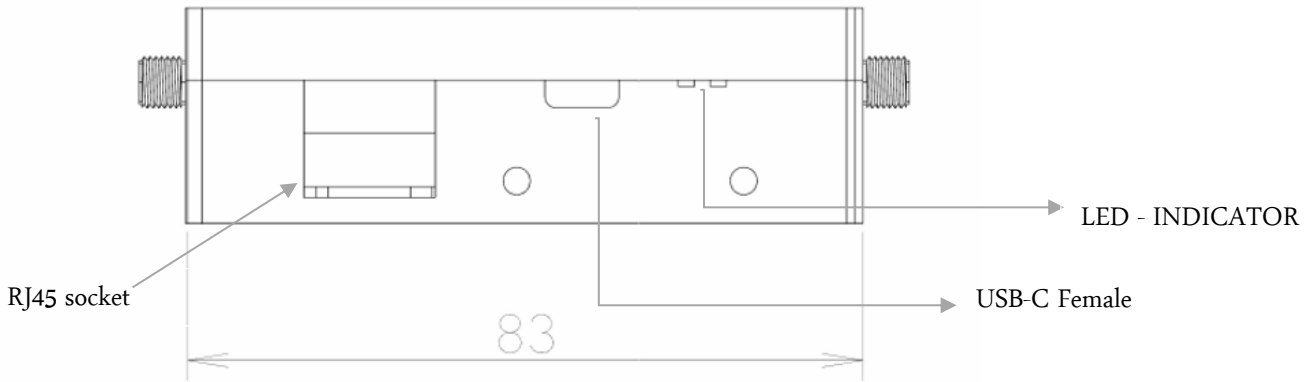

**Isometric View**

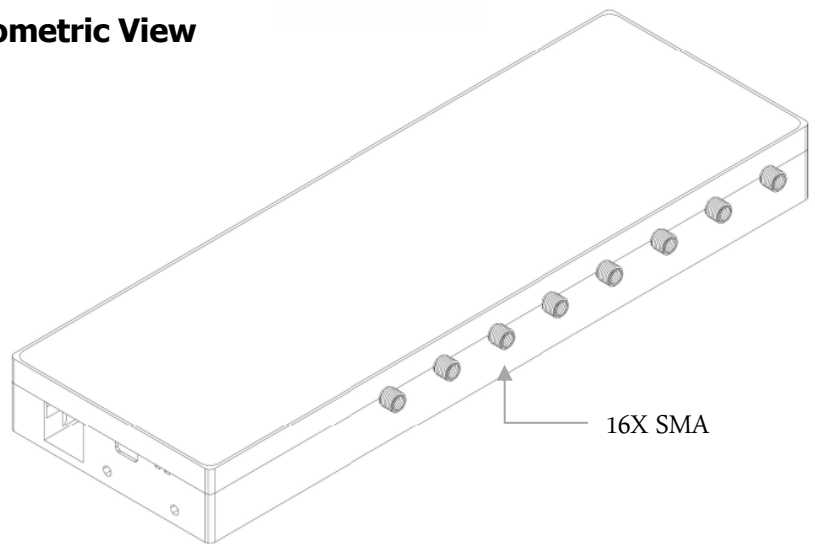
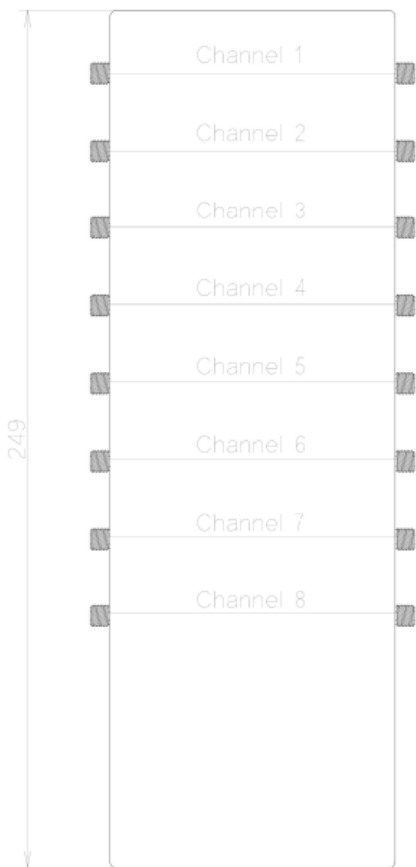

**Right-Side Elevation**

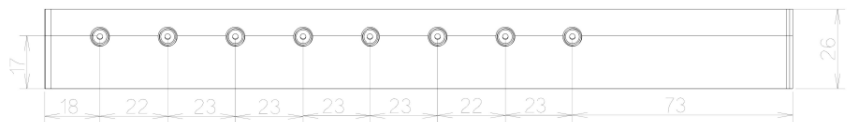

Note: All dimensions are in millimeters (mm). Tolerance  $\pm 0.5$  mm

**PERFORMANCE CURVES**

