

# NXA-B4P

## MESH ATTENUATOR

Programmable Mesh  
Attenuator  
200 to 8000 MHz



### OVERVIEW

The NXA-B4P programmable mesh attenuator is a fully shielded, high-performance, digitally controlled RF attenuator system with six channels. It is designed for automated RF testing applications that require precise signal power control. The NXA-B4P provides excellent attenuation accuracy, a wide dynamic range, and fast operation. Its high performance is achieved through precision attenuator design combined with thorough calibration.

### Applications

- Wi-Fi communication systems
- Cellular systems (5G/4G/3G/2G)
- MIMO, Multipoint Radio Fading
- Automated Test Equipment (ATE)

### Key Features

- **Extended Frequency Range:** Operates across a broad spectrum from 200 MHz to 8 GHz, ensuring versatility for a wide array of testing applications.
- **24/7 Operation:** Engineered for continuous use, supporting fully automated testing workflows to maximize efficiency and reliability in mission-critical environments.
- **Shielded and Precise:** Complete shielding ensures highly accurate and interference-free measurements, ideal for precision testing in demanding RF environments.
- **Customizable Topologies:** Tailored to customer specifications, supporting multiple network topologies for enhanced flexibility and optimized test setups.
- **High Dynamic Range:** Offers up to 95 dB of attenuation with fine-grain control, adjustable in 0.25 dB increments, delivering exceptional precision for signal fading and attenuation simulations.
- **Tailored User Interface:** Custom-designed software interfaces align with specific customer needs, providing an intuitive and efficient control experience for streamlined operations.

## ELECTRICAL SPECIFICATION

Parameter		Min	Typ	Max
Frequency Range (MHz)		200		8000
Impedance ( $\Omega$ )			50	
Channels			4	
Attenuation Range (dB)		95		
Shielding (dB)			90	
Isolation between Channels (dB)			90	
Step Size (dB)		0.25		
Insertion Loss (dB) * Includes theoretical loss of power dividers	< 2 GHz		18	
	< 4 GHz		22	
	< 7.5 GHz		28	
Attenuation Accuracy (dB)			$\pm 0.25$	$\pm 1.5$
Switching Speed ( $\mu$ s)			2	
Maximum Input Level (dBm)			+28 (operating) +33 (absolute max)	
Input IP3 (dBm)			58	
Operating modes	Uni/Bi-Directional GUI control or APIs			
Power	Power over Ethernet (PoE)			
Operating Temperature	-30 °C to +70 °C			
RF connectors	SMA			
Control Interface	Ethernet or USB			
Operating System	Windows, Linux and Mac			
Custom APIs as per user requirements	Yes			

## MECHANICAL SPECIFICATIONS

Parameter	Test Conditions
Power Requirements	Power over Ethernet
Environmental Conditions	Operating Temperature: 0°C to +40°C
Physical Connections	Power Connector: Ethernet/USB Control: Ethernet/USB RF Connectors: SMA – female
Mechanical	Size (1RU): 17.0 x 13 x 1.75 inches Weight: 10 lbs / 4.5 kg

### Functional Diagram

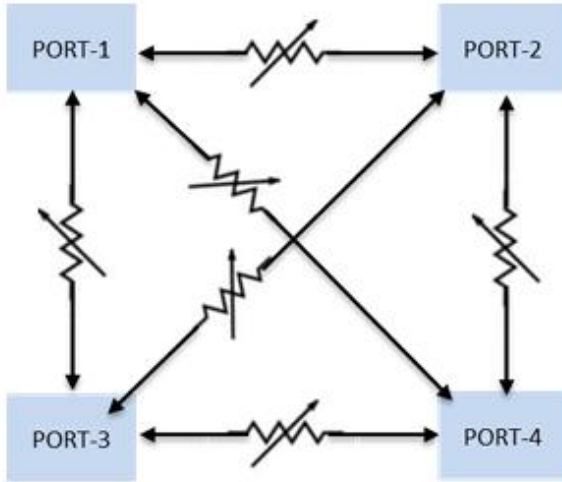

### Attenuator Mapping

Path	Attenuator Channel No.
Path 1 to 2	Channel 1
Path 1 to 3	Channel 2
Path 1 to 4	Channel 3
Path 2 to 3	Channel 4
Path 2 to 4	Channel 5
Path 3 to 4	Channel 6